

Valueline Installation & Service Guide



Please read this manual carefully before attempting installation.

Introduction

Please read this entire service guide prior to beginning installation.

The Valueline reverse osmosis drinking water system has been designed for quick and simple installation and maintenance. You will insure a successful installation and reliable operation by carefully reading this instruction manual and following the operational guidelines. Routine maintenance is essential to the longevity and performance of the system. Filters should be changed every six to twelve months depending on the quality of the feed water supply.

CONDITIONS FOR OPERATION

TFC - Thin Film Composite

Source Water Supply - TFC

Community / Private	Non-Chlorinated
System Pressure	30-100 psi
Temperature	4° - 38° C (40°-100° F)
pH Range	3.0 to 11.0
Maximum Supply TDS Level	2000 mg/L
Turbidity	< 1.0 Net Turbidity (NTU)

Chemical Parameters - TFC

Hardness	< 350 mg/L (< 20 gpg)
Iron (Fe)	< 0.1 mg/L
Manganese (Mn)	< 0.05 mg/L
Hydrogen Sulfide (H ₂ S)	0.00 mg/L
Chlorine (Cl ₂)	0.00 mg/L

CAUTION

DO NOT USE THIS SYSTEM WHERE THE WATER IS MICROBIOLOGICALLY UNSAFE OR OF UNKNOWN QUALITY. THIS SYSTEM IS FOR USE ON POTABLE WATER ONLY. SOURCE WATER EXCEEDING CHEMICAL PARAMETERS REQUIRES PRETREATMENT.

System and Faucet Diagrams

INSTALLATION GUIDE LINE

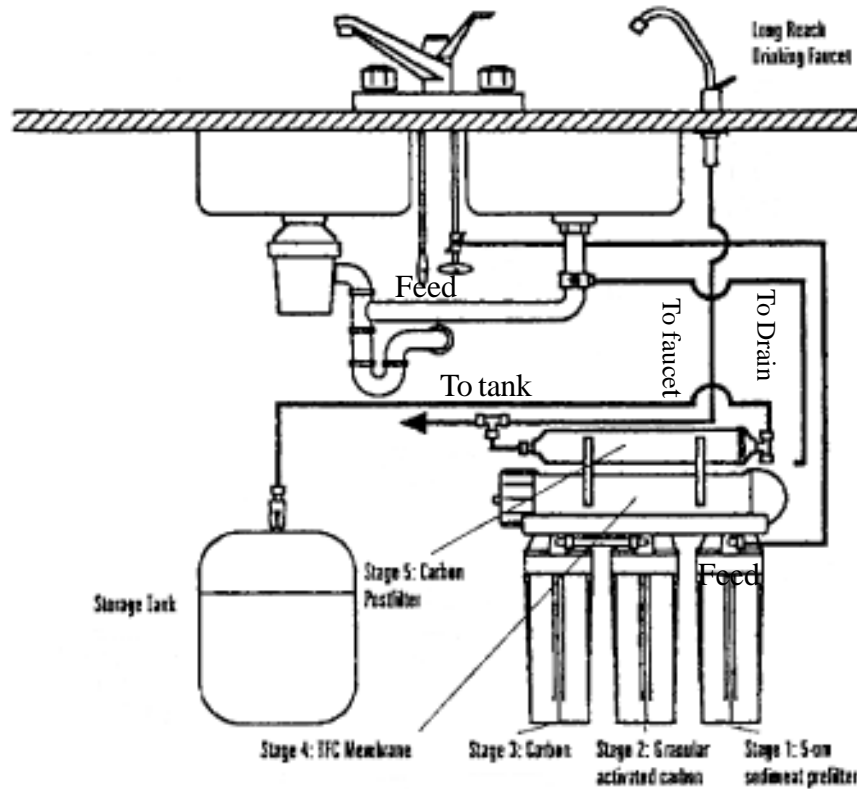

Mounting the Tank Ball Valve

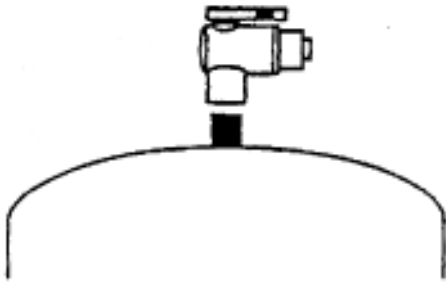

Note: Do not tamper with the air valve on the storage tank. It has been preset and screwed on with blue cap by the manufacturers.

- (1) Wrap the threads on the top of the water storage tank 3 times with plumbers (teflon) tape only. Make sure it is tight, but not overtight.
- (2) Connect the tank ball valve assembly to the top of the water storage tank.
- (3) Connect the tube from the RO module to the water storage tank.

Non-Air Gap Faucet

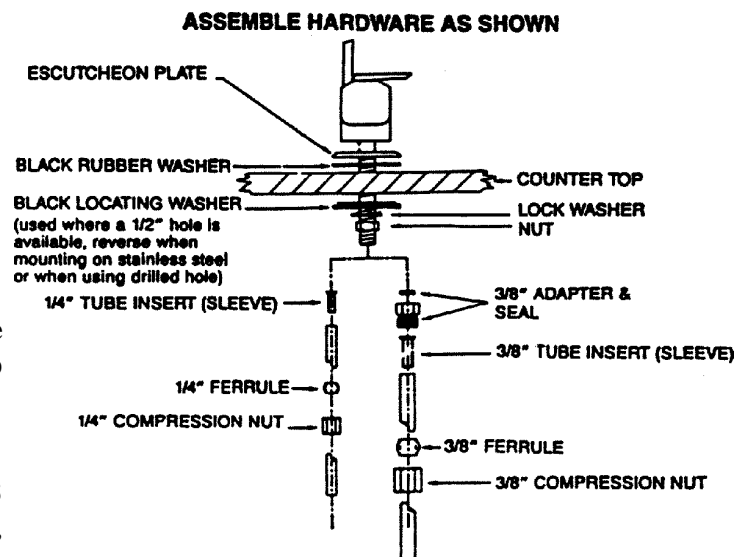

Starting Your Installation

Preparation

Check the following list of components to ensure that all parts are packed with your system.

- 1 - Storage Tank
- 1 - RO System
- 1 - Faucet
- 1 - Installation Kit

Determine the location for the installation of the RO system. Avoid locations where the system might come in contact with hot water pipes or other hazards.

Determine the location for the faucet. Check to see that drilling the faucet hole will not damage pipes or wires running underneath the sink.

Determine the location for the storage tank. A maximum distance from tank to faucet of 15 feet is possible. The system will produce a faster flow at the faucet with the shortest tubing run from tank to faucet.

Fittings and Tubing

Compression fittings are used throughout the system. To insure a optimal seal, tubing should be cut with the end square. An angled cut or distortion of the tubing will not provide an efficient seal and may cause leaks.

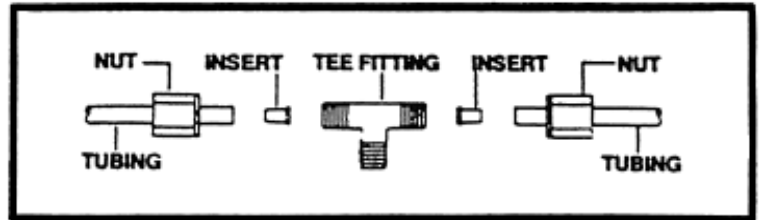

Source and Drain Water Saddle Valves

Shut Off the Water

Locate the water shut-off valve for the cold water feed line you choose to use for the supply. Accidentally hooking up the system to the hot supply line will permanently damage the membrane (See Conditions for operation). To assure you are using the cold water line, turn on both the hot and cold faucet. After the water is warm to the touch, feel the pipes under the sink. It will be easy to identify the hot and cold pipes.

Close the cold water valve. Turn on the cold water faucet only to assure that the line is completely shut off and the line is drained. If no shut off valve is located under the sink, turn off the main supply at the entry to the house.

Installing Supply Feed

(A) **Flex Line:** Loosen nut and separate cold water riser tube from faucet shank. Gently bend riser tube so that slip joint fits onto faucet shank. Replace the existing cone washer with new washer provided in installation kit onto cold water riser tube. Reinstall riser tube onto slip joint adapter and tighten.

(B) **Solid Copper Riser Tube:** Same procedure as flex tubing except you must cut a piece of the riser tube about 3/4" to 1" so the slip joint adapter can fit between faucet and riser tube (Teflon tape must be used on slip joint adapter to prevent leaks).

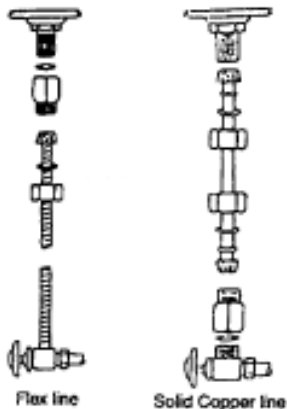

Installing the Drain Clamp

Select a location for the drain hole based on the design of the plumbing. Position the drain outlet saddle on the drain pipe. Allow adequate space for drilling. Tighten the bolts evenly on both sides. Avoid overtightening.

Using the opening in the drain outlet saddle as a guide, drill a 1/4" hole in the drain pipe. Clean debris from the saddle and threads.

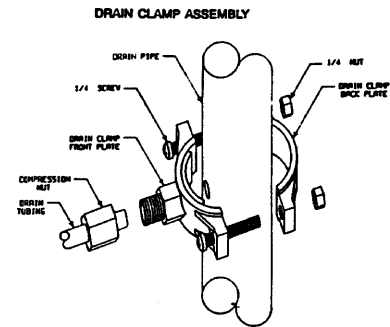

NOTE: Some states require the use of an air gap faucet. Check your local plumbing code to assure compliance. Locate the drain connection away from the garbage disposal to prevent potential contamination and system fouling.

Installation - Product Water Faucet

Drilling the Faucet Hole

The product water faucet may be installed on any flat surface at least 2" in diameter. Check the underside of the location for interference.

Porcelain/Enamel Sinks

A 3/8" variable speed drill drill is recommended for this procedure.

A spring loaded Relton style drill set is strongly recommended to prevent chipping.

The plastic sleeve supplied on the pilot drill is to be positioned on the drill bit against the drill chuck. This prevents the chuck from contacting the porcelain after the pilot hole has been completed.

Avoid high motor RPM during the initial cutting of the porcelain as this can cause chipping.

Using a carbide tipped drill bit, drill a pilot hole completely through the porcelain and the material underneath.

Place the spring loaded porcelain saw into the drill chuck. Make sure the pilot guide is inserted tightly. Insert the pilot guide into the pilot hole. Push down gently on the drill motor to apply light pressure to the porcelain surface. Start the drill motor turning as slowly as possible.

After the initial cut has started, motor speed may be gradually increased. The cut may require three to four minutes to complete. Going faster could result in excessive chipping.

Be sure a complete ring has been cut through the porcelain to the material underneath.

Place the finish hole saw into the drill chuck. Make sure the pilot guide is inserted tightly. Insert the pilot guide into the pilot hole. Begin cut using a slow speed and light pressure until the porcelain has been penetrated to the material underneath.

Stainless Steel Sink

Make a small indent to mark the desired drilling location using a center punch. Drill a pilot hole with a 1/8" metal drill bit. Enlarge the hole using a 3/8" metal drill bit.

Tile Counter Top

Follow the procedures outlined in the Porcelain/Enamel Sinks section.

Faucet Installation

Once the hole has been drilled in the sink, the faucet may be located in the hole. Be sure the faucet body, faucet base, and the rubber faucet base washer are in place above the sink.

Install the star lock washer and nut, then tighten firmly while aligned faucet in the desired direction.

Additional Point of Use Connection

NOTE: Ice makers typically use 1/4" tubing as the water feed line. Use a reducing union fitting to make this connection

To connect an additional point of use (ice maker, extra faucet, etc.), place a 'T' connector in the 1/4" line between the faucet and the RO system.

Drilling with the recommended Relton cutter

EASY AS . . .



The Pilot Drill is used to drill a hole completely through to provide a guide for both the Porcelain Saw and Finish Hole Saw.



The Porcelain Saw is used to cut through the porcelain surface only. This saw cuts a smooth, chip-free, beveled groove through the porcelain to the metal base.



The Finish Hole Saw is used to cut the remaining metal through to create the hole of the desired finish size.

Activation, Troubleshooting, and Maintenance

Activating the System For the First Time

Make sure all water supply/drain lines are secure and free from leakage. Slowly turn the saddle valve counterclockwise until fully open. Check stem seal for leakage. If necessary tighten stem nut lightly.

Turn storage tank valve one quarter turn counterclockwise to open the valve (the handle should be in line with the tubing as it enters the connection).

Open the product water faucet and let the water flow until all the air has been expelled from the system. This will take about an hour.

Close the product water faucet. In 30 minutes, check the connections for leaks and correct if necessary.

Do Not Use the First Two Reservoirs of Water

Allow the reservoir to fill for 4-6 hours. Dispense this water to drain. This process removes the factory installed sanitizing solution from the entire system and sends it to the drain. Repeat this process one more time. Allow the tank to fill for 4-6 hours and dispense this water to the drain.

Maintenance- Imperative to follow the sequence as outlined

Note that filters are labeled for easy servicing.

- 1) Open the RO faucet and let the tank drain completely. Leave the faucet open until the filter change is complete.
- 2) Remove the pre-sediment cartridge.
- 3) Remove the pre-carbon cartridge.
- 4) Remove the membrane cartridge - The membrane may be reused indefinitely as long as the TDS level and other troubleshooting guidelines are met.
- 4) Remove the post-carbon cartridge.
- 5) Install the new filters.
- 6) Turn on the system and inspect for leaks.
- 7) Drain the first tank of water after changing the filters before drinking. When the membrane is changed, drain the first two tanks of water before drinking.

Troubleshooting

Problem

Reason

Solution

Water has an offensive odor
Water has an offensive odor
Water has an offensive odor

Carbon post filter is depleted
Sediment/Carbon filters are depleted
Membrane depleted or fouled

Drain storage tank and replace post filter
Replace filters, clean system
If monitor indicated red light, drain storage tank, replace membrane, and sanitize system

Not enough product water pressure

Storage tank air pressure charge is low

Empty storage tank and set pressure to 8 psi (55kPa)

Not enough water

Low water pressure

If line pressure is below 30 psi install a booster pump

Not enough water

Water supply is blocked

Clear restriction, rotate valve on feed water

Not enough water

Storage tank is depleted

Consider an increase in tank or membrane capacity

Not enough water

Clogged pre-filter cartridge

Replace prefilter, drain tank and sanitize system

No drain water

Clogged flow restrictor

Replace membrane

No water

Water supply is turned off

Turn water on

Under sink is wet

Leak from valve, faucet, or fitting

Dry everything with towels to isolate leak, identify, and fix

Red service light

Depleted membrane or low usage

Run faucet for 10 seconds and check again, if persists, change membrane



Valueline Limited Warranty

The Valueline reverse osmosis system is warranted to be free from defects in materials and workmanship under normal use within the operating parameters listed below. For a period of twelve months from the date of purchase Valueline will repair or replace any part of the reverse osmosis system with the exception of the filters and battery.

Conditions of Warranty

The above warranty does not apply to any part of the Valueline reverse osmosis system that is damaged because of neglect, misuse, alteration, accident, misapplication, physical damage, fouling, and/or scaling of the membrane by minerals, bacterial attack, sediment or damage caused by fire, freezing, hot water, or an act of God.

Valueline assumes no warranty liability in connection with this reverse osmosis system other than as specified herein. Valueline shall not be liable for consequential damages of any kind or nature due to the use of Valueline products.

Warranty Service

Warranty service will be provided by Valueline under the following conditions:

- 1) Contact your local dealer who will obtain return authorization instructions.
- 2) Ship the unit or part freight prepaid for warranty evaluation or service. Unit must be returned in the original carton or packaged to prevent possible damage. Systems or parts covered under the warranty shall be repaired (or, at our option replaced) and returned without charge.

CONDITIONS FOR OPERATION

Source Water Supply - TFC

Community / Private	Non-Chlorinated
System Pressure	30-100 psi
Temperature	4° - 38° C (40°-100° F)
pH Range	3.0 to 11.0
Maximum Supply TDS Level	2000 mg/L
Turbidity	< 1.0 Net Turbidity (NTU)

Chemical Parameters - TFC

Hardness	< 350 mg/L (< 20 gpg)
Iron (Fe)	< 0.1 mg/L
Manganese (Mn)	< 0.05 mg/L
Hydrogen Sulfide (H ₂ S)	0.00 mg/L
Chlorine (Cl ₂)	0.00 mg/L